



LATHRUP INDUSTRIES, INC.

CONVEYOR MANUFACTURERS

CDLR Catalog

Lathrup Industries, Inc.

42300 W. Nine Mile Rd.

Novi, MI 48375

Phone: (248) 349-1009

Fax: (248) 349-1062

Table of Contents

Standard Specifications	pg. 2
CDLR Dimentions Chart	pg. 3
CDLR Drive Options	pg. 4
CDLR Curve	pg. 5
CDLR Curve Roller Options	pg. 6
Chain Conveyor	pg. 7
Chain Transfer	pg. 8
Blade & Pin Stops	pg. 9

Standard Specifications

Introduction

A Chain Driven Live Roller conveyor is a conveyor where the product rides directly on the carrying rollers. These carrying rollers have sprockets welded to them, which in turn are powered by a chain. Due to the physical design of our chain driven live roller, there are two different types of conveyor widths. These are "effective conveyor width" and "between frames width." See the illustration on page 3.

Frame

Our frames are structural channels with welded cross members. End couplers are welded on the ends of these channels for bolting sections together. Then the frames will receive one coat of shop primer and one coat of industrial enamel, your choice of color.

Chain Guard

Our chain guards are made from 10 gage formed steel. The lower section is welded to the bottom of the frame while the top section is bolted to the top of the sideframe. The top section is painted safety yellow.

Rollers

Various diameters of steel tubing are used with 2-type A sprockets welded to it. The chart on page 3 has the standard sprocket locations, or customer to specify special locations. The bearings for these rollers are sealed and grease packed.

Axle

1.9" Dia. Roller - 7/16" Hex-pin retained, spring retained optional.

2-1/2" and 2-9/16" hex-pin retained. Spring retained optional.

4" and 5" Dia. Rollers - 1-7/16" round - keeper bar and pin retained.

CDLR Spurs

30 and 45 spurs are available. We build these to your specifications, with the length of the long rail and the effective width. Lathrup can build spurs with the same frame and roller variations as straight sections.

Other Options

This catalog contains the guidelines for our chain driven live roller conveyors. Specialized variations can be easily arranged. Multiple lanes, notches, special drive bases, etc. can be provided. We can build customized conveyors directly from your blueprints.

Typical CDLR Section

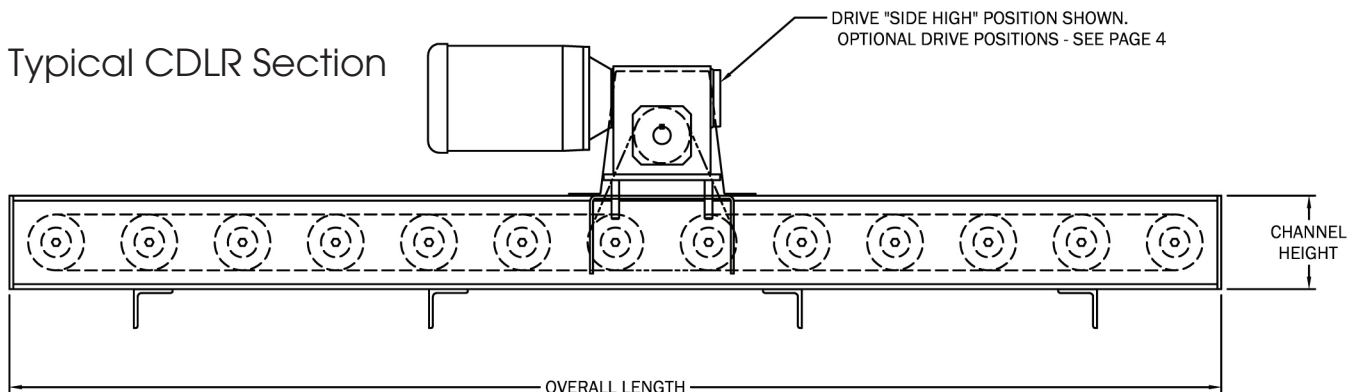

Chain Driven Live Roller Conveyor

Standard Dimentions

Below is a list of standard dimensions for a chain driven live roller conveyor (CDLR). Lengths can range up to 20 feet, with effective widths up to 120 inches. CDLR conveyors are available with semi precision or precision internal bearings, and flange or pillow block mount external bearings.

Special Close Roller Centers

By means of every other roller powered, double delta drive, or every roller powered both sides, special close roller centers can be achieved. For more information contact one of our sales representatives.

ROLLER DIA.	CHAIN	SPROCKET	ROLLER CENTERS	FRAME	OPTIONAL SIDEFAME		A	B	C	D
					Channel	Angle				
1.9	RC40	40A18	3_1/2" & UP IN 1/4" INCREMENTS	5 x 6.7# [---	3_1/2 x 2_1/2 x 5/16	3_1/4"	2_1/2"	1_1/8"	1_1/8"
1.9	RC50	50A15	3_3/4" & UP IN 5/16" INCREMENTS	5 x 6.7# [---	3_1/2 x 2_1/2 x 5/16	3_1/4"	2_1/2"	1_1/8"	1_1/8"
1.9	RC60	60A13	4_1/8" & UP IN 3/8" INCREMENTS	6 x 8.2# [4 x 5.4#	4 x 3 x 5/16	4"	3"	1_1/4"	1_1/4"
2_1/2	RC40	40A22	4_1/4" & UP IN 1/4" INCREMENTS	5 x 6.7# [---	3_1/2 x 2_1/2 x 5/16	3_1/4"	2_1/2"	1_1/8"	1_1/8"
2_1/2	RC50	50A17	4_3/8" & UP IN 5/16" INCREMENTS	5 x 6.7# [---	3_1/2 x 2_1/2 x 5/16	3_1/4"	2_1/2"	1_1/8"	1_1/8"
2_1/2	RC60	60A15	4_1/2" & UP IN 3/8" INCREMENTS	6 x 8.2# [4 x 5.4#	4 x 3 x 5/16	4"	3"	1_1/4"	1_1/4"
2_9/16	RC40	40A22	4_3/4" & UP IN 1/4" INCREMENTS	5 x 6.7# [---	3_1/2 x 2_1/2 x 5/16	3_1/4"	2_1/2"	1_1/8"	1_1/8"
2_9/16	RC50	50A18	4_3/8" & UP IN 5/16" INCREMENTS	5 x 6.7# [---	3_1/2 x 2_1/2 x 5/16	3_1/4"	2_1/2"	1_1/8"	1_1/8"
2_9/16	RC60	60A15	4_1/2" & UP IN 3/8" INCREMENTS	6 x 8.2# [4 x 5.4#	4 x 3 x 5/16	4"	3"	1_1/4"	1_1/4"
2_9/16	RC80	80A13	5_1/2" & UP IN 1/2" INCREMENTS	6 x 8.2# [4 x 5.4#	4 x 3 x 5/16	4"	3"	1_1/4"	1_3/4"
3_1/2	RC60	60A20	6" & UP IN 3/8" INCREMENTS	7 x 9.8# [5 x 6.7#	5 x 3 x 5/16	4"	3_1/2"	1_1/4"	1_1/4"
3_1/2	RC80	80A16	6_1/2" & UP IN 1/2" INCREMENTS	8 x 11.5# [6 x 8.2#	6 x 4 x 3/8	4"	4"	1_1/4"	1_3/4"
4	RC60	60A22	6_3/8" & UP IN 3/8" INCREMENTS	7 x 9.8# [5 x 6.7#	5 x 3 x 5/16	4"	3_1/2"	1_1/4"	1_1/4"
4	RC80	80A17	7" & UP IN 1/2" INCREMENTS	8 x 11.5# [6 x 8.2#	6 x 4 x 1/2	4"	4"	1_1/4"	1_3/4"
5	RC80	80A20	8" & UP IN 1/2" INCREMENTS	10 x 15.3# [7 x 9.8#	7 x 4 x 1/2	4"	5"	1_1/4"	1_3/4"

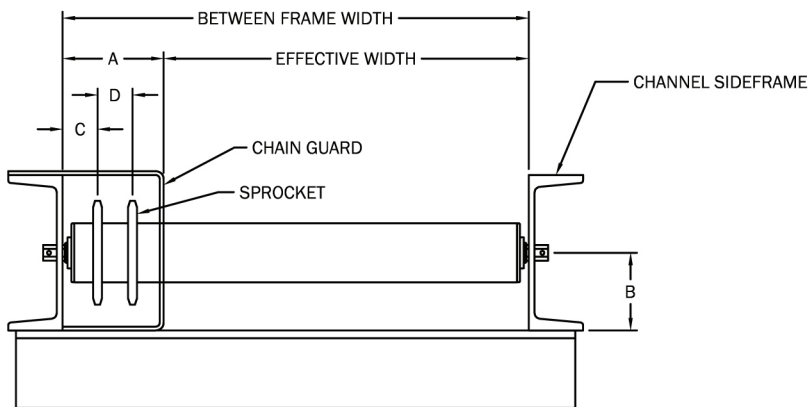

Standard-Rollers Low

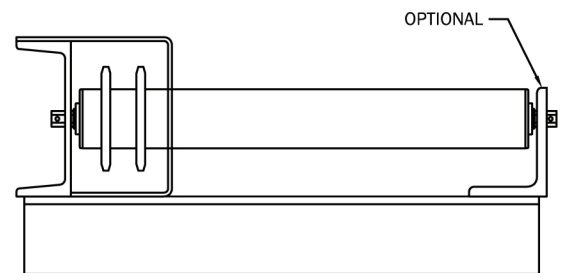

Optional-Rollers High One Side

CDLR Drive Options

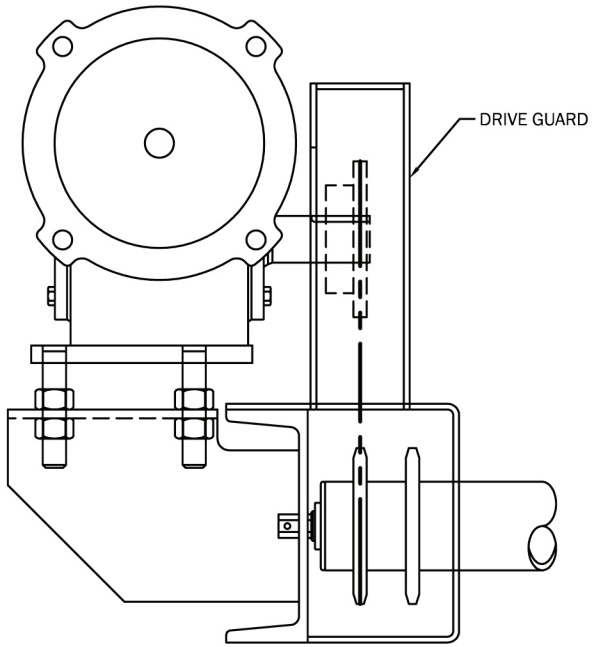

Drive Mounted Side High

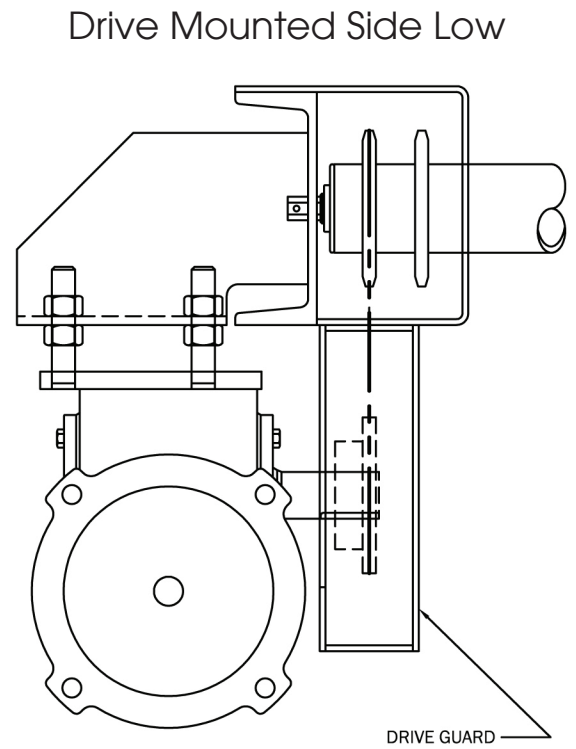

Drive Mounted Side Low

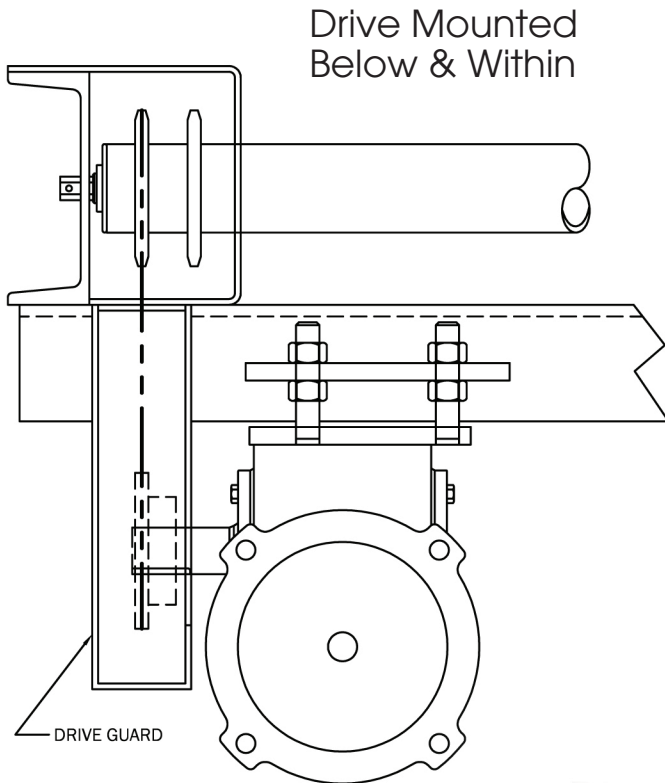

Drive Mounted Below & Within

CDLR Curve

Chain Driven Live Roller Curves

We offer chain driven live roller curves with a range of 10° degrees to 180° degrees, either with a drive or slave driven. Many times curves in a system will regulate the width of the conveyor for the entire system, in that the product may require “extra space” to accommodate the turn. This “extra space” depends upon the width and length of the product. The inside radius of the conveyor should be greater than the longest product dimension.

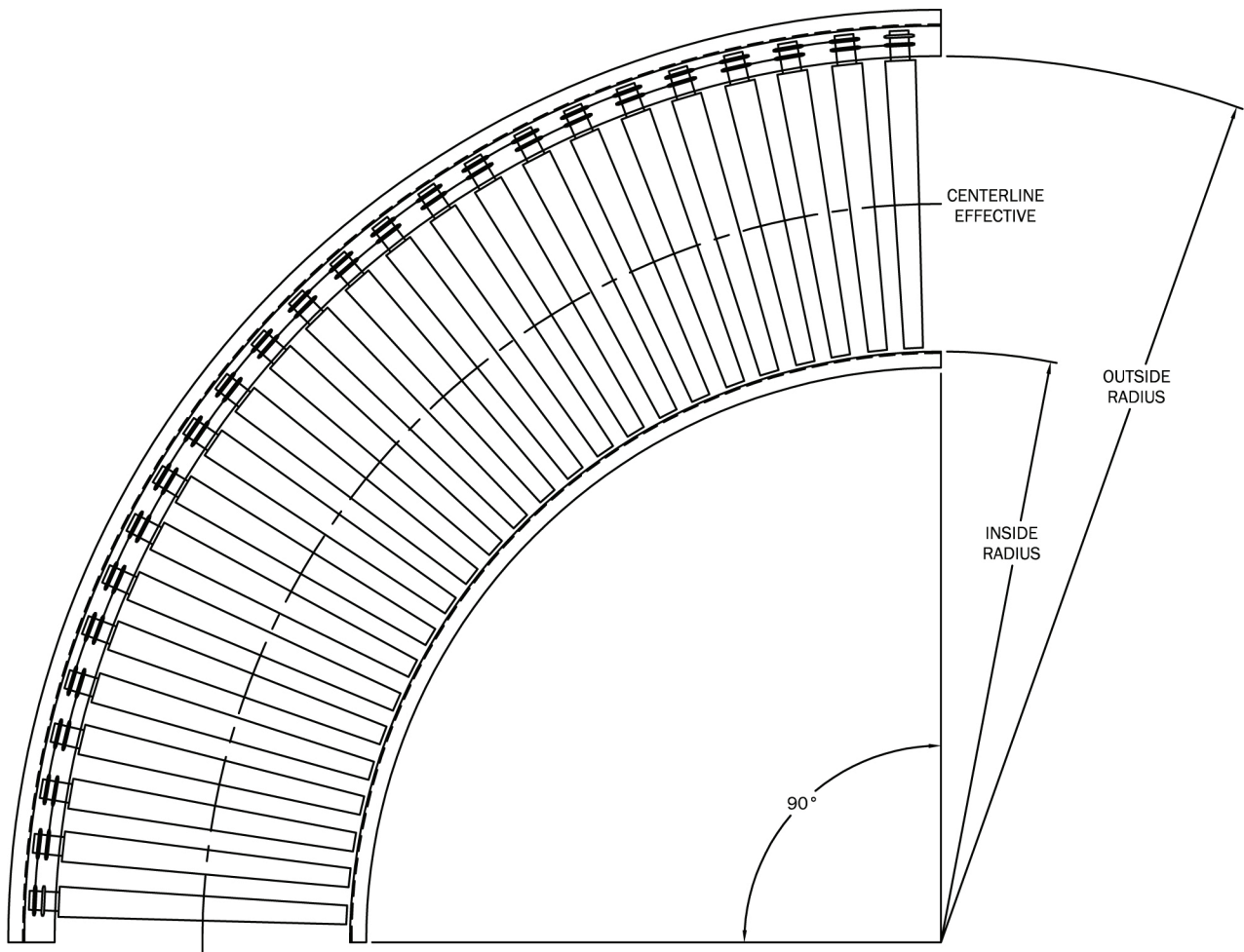

Roller Options for CDLR Curve

Tapers & Straight Rollers

Below are the three roller options we offer for CDLR curves. Any roller 3_1/2" nominal diameter and larger are limited to the straight style only. However, any roller 2_9/16" nominal diameter and smaller can have the straight roller or the custom "true" taper. The 1.9" nominal diameter is the only size roller which can have any of the three styles.

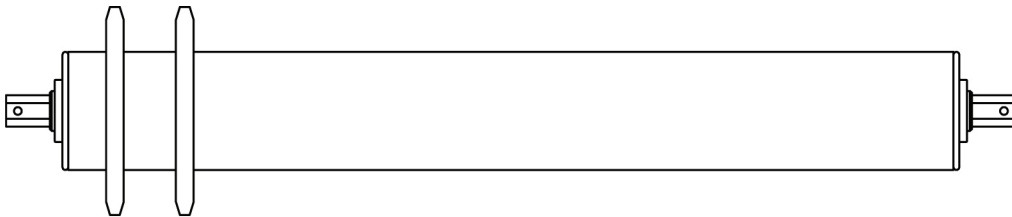

Straight Roller

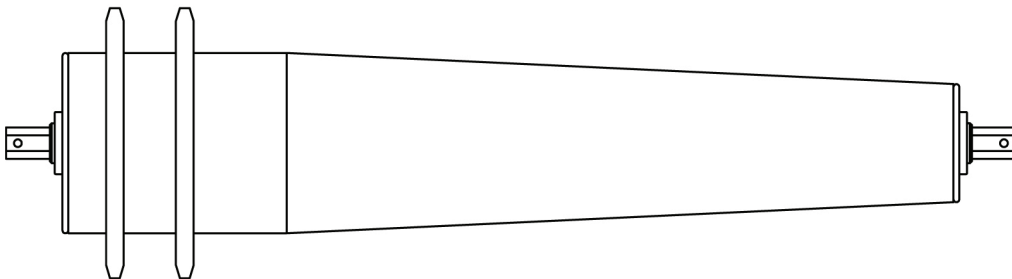

Standard Tapers up to 39_1/2" BF

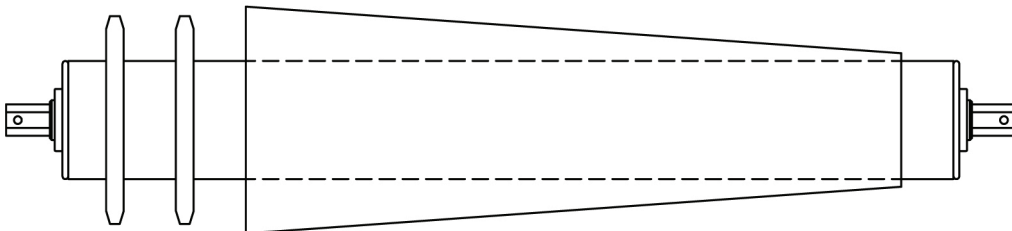

Custom "True" Tapers up to 64" BF

Chain Conveyor

Chain Conveyor

Lathrup's chain conveyors are built with heavy welded frames, with structural tube chain rails. The chain track for C60 and C80 is UHMW polyethylene, which provides wear resistance, quiet operation, and reduces power requirements. For increased load capacity, we use a special alloy steel track on C80, C100, and RC120 chain.

We use "C" series, straight side bar, flat plate chain on sizes C60 through C100, which reduces product damage and wear compared to regular roller chain. Contact a Lathrup representative for variable chain options. Padded chain with non-marring pads assembled to the chain for conveying glass or painted parts is just one example.

STANDARD MODELS AVAILABLE					
MAX. CAPACITY	CHAIN TYPE	CHAIN TRACK	MIN. TOP OF CHAIN	MIN. CHAIN CENTERS	HORSE POWER
500 lbs.	C60	UHMW	16"	8"	1/2
1,500 lbs.	C60	UHMW	16"	9"	1/2
2,000 lbs.	C60	UHMW	16"	9"	3/4
3,000 lbs.	C80	UHMW	18"	14"	1
4,000 lbs.	C80	STEEL	19"	16"	2
6,000 lbs.	C100	STEEL	19"	26"	3
8,000 lbs.	RC120	STEEL	28"	27"	5

This chart is based on two strands at 30 F.P.M. Contact a Lathrup representative for additional capacities and sizes.

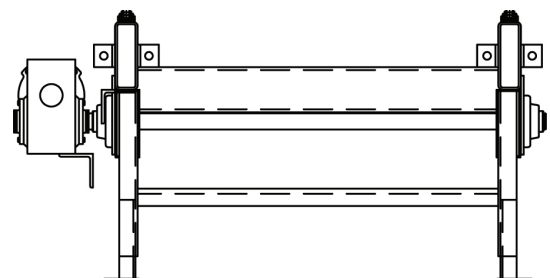
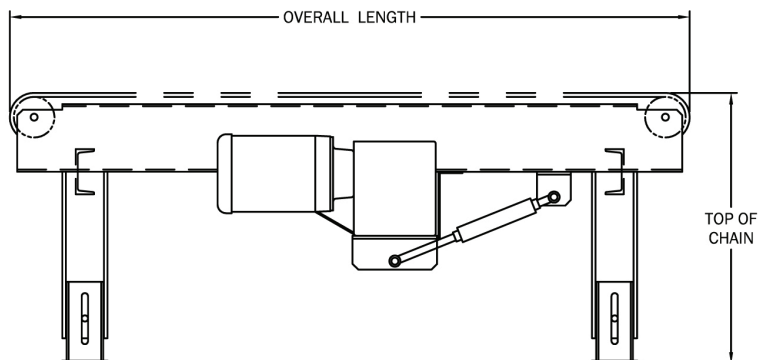
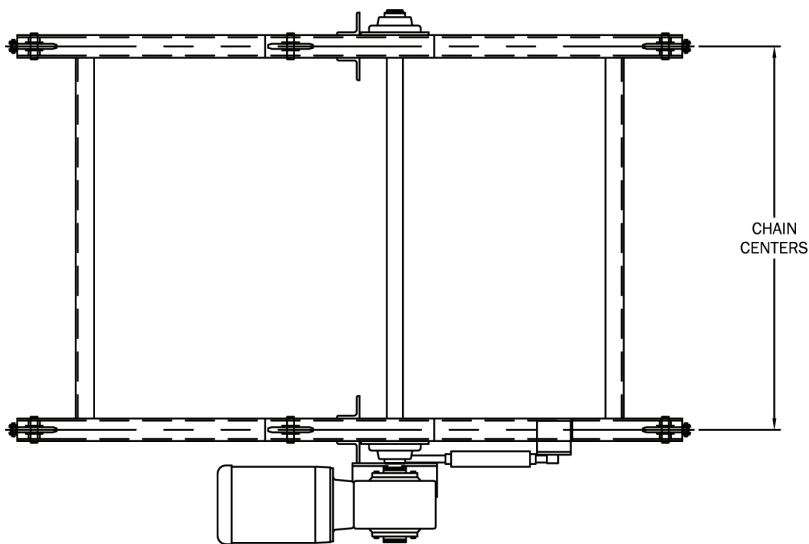

CDLR Accessories

Chain Transfer

Chain transfers are used to transfer products 90° onto an adjacent conveyor. For pallets or other products with a sturdy conveying surface, chain transfers are an ideal application for this 90° flow.

Air Bag of Cylinder Cam Actuated

Standard Capacities up to 8,000 lbs.

Available with 16" Minimum Top of Roller Height

Built to Your Specifications

Standard Specifications

Lathrup's chain transfers are built with heavy duty welded frames, with structural tube chain rails. The chain track for C60 and C80 is UHMW polyethylene, which provides wear resistance, quiet operation, and reduces power requirements. For increased load capacity, we use a special alloy steel track on C80, C100, and RC120 chain.

We use "C" series, straight side bar, flat plate chain on sizes C60 through C100, which reduces product damage and wear compared to regular roller chain. Contact a Lathrup representative for variable chain options. Padded chain with non-marring pads assembled to the chain for conveying glass or painted parts is just one example.

STANDARD MODELS AVAILABLE					
MAX. CAPACITY	CHAIN TYPE	CHAIN TRACK	MIN. TOP OF CHAIN	MIN. ROLER CENTER (AT CHAINS)	HORSE POWER
500 lbs.	C60	UHMW	16"	1.9" DIA. = 4_3/8" 2_1/2" DIA. = 5_5/16"	1/2
1,500 lbs.	C60	UHMW	16"	2_1/2" DIA. = 6" 3_1/2" DIA. = 7_1/2"	1/2
2,000 lbs.	C60	UHMW	16"	2_1/2" DIA. = 6" 3_1/2" DIA. = 7_1/2"	3/4
3,000 lbs.	C80	UHMW	18"	2_1/2" DIA. = 6_3/4" 3_1/2" DIA. = 7_1/2"	1
4,000 lbs.	C80	STEEL	19"	2_1/2" DIA. = 6_3/4" 3_1/2" DIA. = 7_1/2"	2
6,000 lbs.	C100	STEEL	19"	3_1/2" DIA. = 8_1/2" 4" DIA. = 9"	3
8,000 lbs.	RC120	STEEL	28"	3_1/2" DIA. = 8_1/2" 4" DIA. = 9"	5

This chart is based on two strands at 30 F.P.M. Contact a Lathrup representative for additional capacities and sizes.

Lift & Other Options

For lift, we use air bags as a standard. Plumbed to a common air connection, these air bags are simple, maintenance-free devices. Heavy duty cylinder operated cams are optional, which are ideal for products that require level lifting. Other options include three or more chain strands and "thru-frame" extensions.

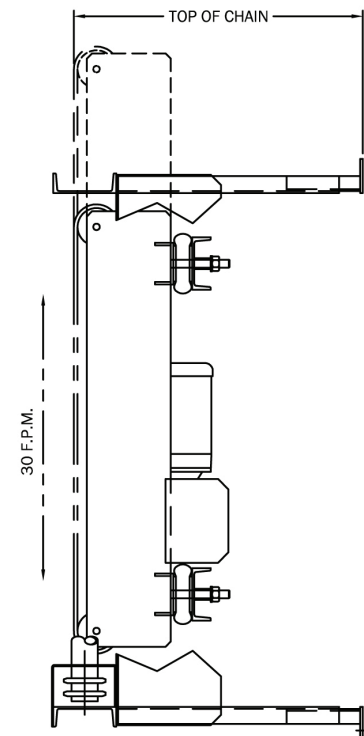
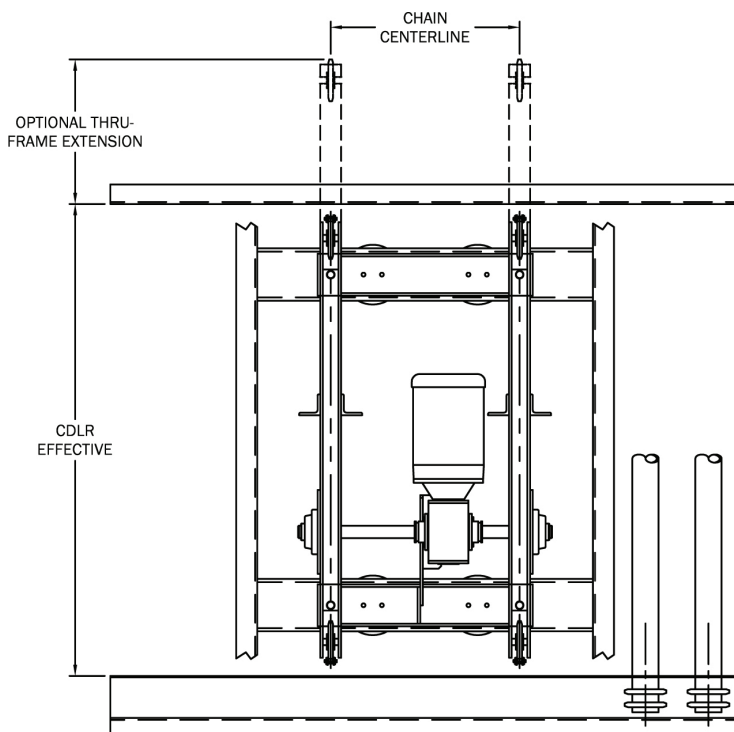

CDLR Accessories

Blade Stop

Blade stops are mounted to CDLR straight sections, where the pneumatically operated blade protrudes between rollers to stop the product in a conveying line. To better suit your material handling needs, please specify the between frame width, effective conveying width, roller diameter and spacing, channel size, and product height.

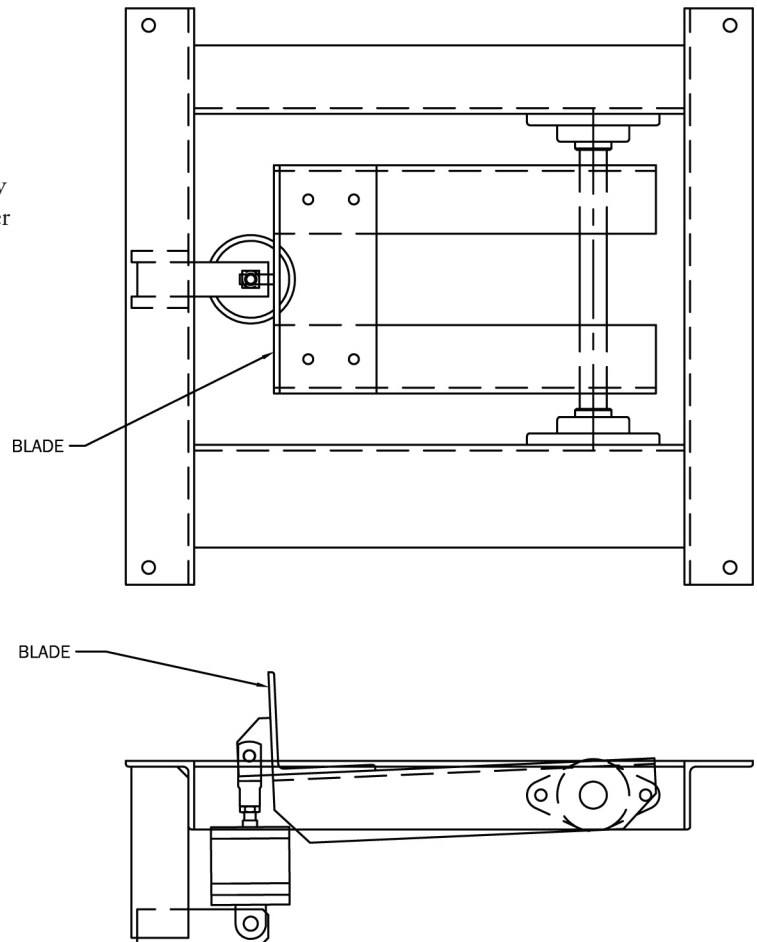

Pin Stop

Pin stops are designed for round products such as tires, barrels, pails, etc. These devices are mounted to CDLR straight sections, where the pneumatically operated pins protrude between rollers to stop the product in a conveying line. To better suit your material handling needs, please specify the between frame width, effective conveying width, roller diameter and spacing, channel size, product diameter and height.

