

LATHRUP INDUSTRIES, INC.
FOR APPROVAL ONLY!

SUBMITTED: _____

APPROVED WITHOUT CHANGES
 APPROVED WITH CHANGES NOTED
 NOT APPROVED – RESUBMIT

BY: _____

DATE: _____

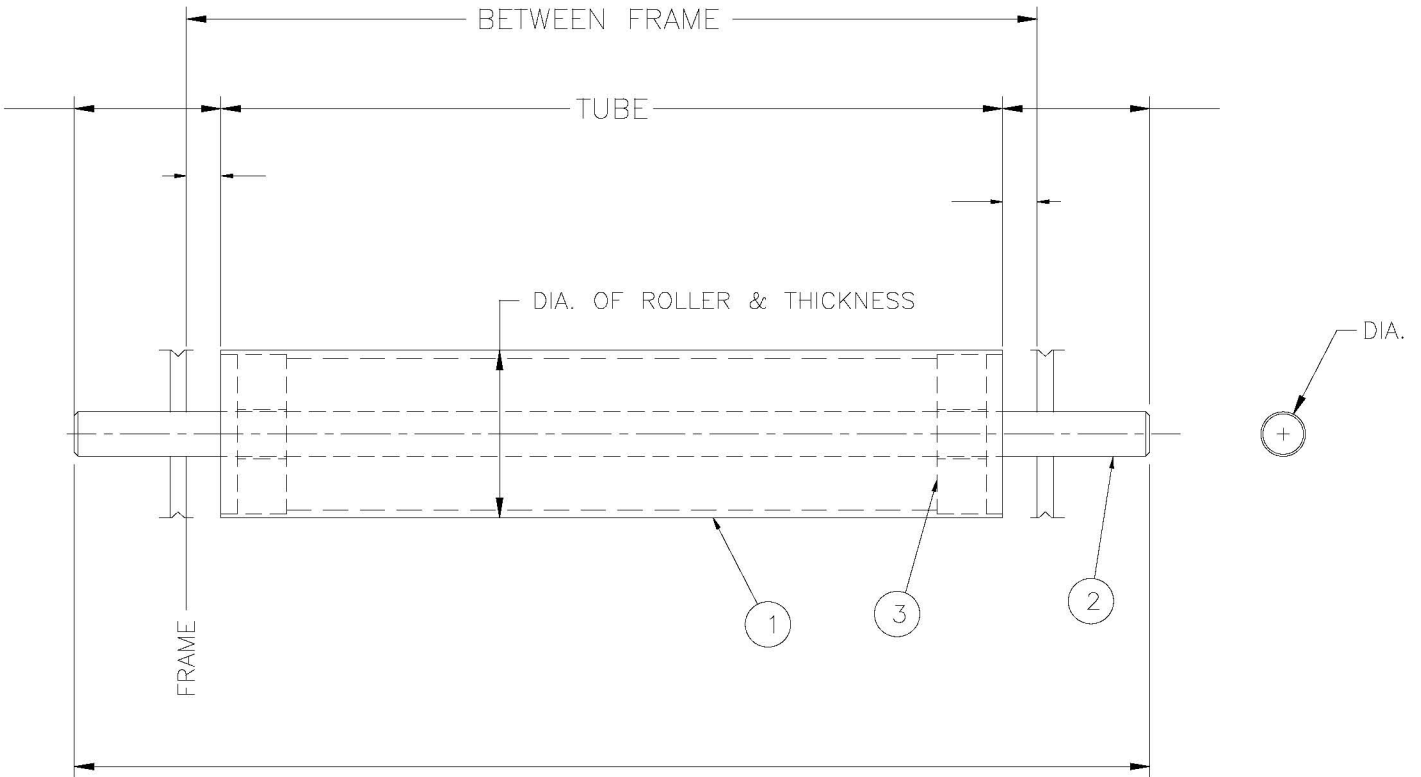

NOTE: MAX FRAME THICKNESS = 1/4"

() REQD

3	2	STOCK	SLUG
2	1	STOCK	DIA. OF SHAFT
1	1	STOCK	DIA. ROLLER & THICKNESS
DET.	QTY.	PART NUMBER	MATERIAL & DESCRIPTION

DESCRIPTION:

GRAVITY PULLEY ROLLER – BF

SCALE: NONE	ENGINEERED BY:	DRAWN BY:	DATE:
ACAD .DWG:	ITEM NUMBER:	SHIP DATE:	JOB NUMBER:

COMPANY NAME:

LATHRUP INDUSTRIES INC.
42300 W. NINE MILE RD., NOVI, MI 48375
PH. (800) 536-3003/FAX (248) 349-1062

DRAWING NUMBER: